

# R8/17 ... L120/11

## Version: C SEF I1

en

### Assembly and Operating Instructions

## Radio controlled sun protection drives with locking system

Important information for:

- Fitters / • Electricians / • Users

Please forward accordingly!

These instructions must be kept safe for future reference.

2010 300 842 0 07/05/2018

Becker-Antriebe GmbH  
Friedrich-Ebert-Straße 2-4  
35764 Sinn/Germany  
[www.becker-antriebe.com](http://www.becker-antriebe.com)



**BECKER**

# Table of contents

General .....	3
Warranty .....	4
Safety instructions .....	4
Instructions for the user .....	4
Instructions for installation and commissioning.....	5
Intended use .....	8
Assembling and disassembling the plug-in connecting cable.....	9
Assembling the plug-in connecting cable.....	9
Disassembling the plug-in connecting cable for tubular drives dia. 45 and dia. 58 ....	10
Installation.....	11
Assembling the drive .....	11
Undoing the mounting pin.....	11
Drive adapter safety catch .....	12
Assembling the drive adapter with safety catch on the drive shaft.....	12
Disassembling the drive adapter with safety catch on the drive shaft .....	12
Assembling and disassembling the drive adapter with separate drive adapter safety catch.....	12
Assembling and disassembling the drive adapter with screw connection .....	13
Mounting the drive in the tube .....	13
Commissioning.....	15
Programming the master transmitter .....	16
Checking that the running direction is correct.....	17
Setting the limit positions.....	18
Deleting the limit positions .....	20
Intermediate position I in the down direction.....	20
Intermediate position II in the up direction .....	21
Programming additional transmitters .....	22
Deleting transmitters.....	23
Overwriting the master .....	24
Disposal .....	25
Maintenance .....	25
Technical data dia. 45 .....	26
Technical data dia. 58 .....	27
What to do if...?.....	28
Declaration of conformity .....	29

## General

These tubular drives are high-quality products with the following features:

- Optimised for sun protection applications with locking system
- Locking limit position and unlocking limit position freely programmable
- Automatic detection of upper limit position
- Automatic detection of lower limit position when the locking system is activated
- Several drives can be operated in parallel
- Compatible with existing drives with electronic limit switching (4-core connecting cable)
- Comprehensive range of the drive manufacturer's control units can be used
- Smooth operation of the system and the drive increases the service life
- Individual, group and central radio control
- No need to run wires to a switch or relay control device
- Any combination of drive and transmitter possible
- Simple to set the limit positions with the transmitter
- Setting of an intermediate position I in the down direction possible
- Setting of an intermediate position II in the up direction possible
- Flexible radio grouping; can be altered at any time with no need to install/uninstall
- For plug-in connecting cable

Please observe these Assembly and Operating Instructions when installing and setting the equipment.

The date of manufacture comes from the first four digits of the serial number.



The numbers 1 and 2 indicate the year and the numbers 3 and 4 indicate the calendar week.

Example: 24th calendar week in 2012

Ser. No.:	1224XXXXX
-----------	-----------



## Explanation of pictograms

	<b>CAUTION</b>	CAUTION indicates a hazardous situation which, if not avoided, could result in injury.
	<b>ATTENTION</b>	ATTENTION indicates measures that must be taken to avoid damage to property.
		Denotes user tips and other useful information.

## Warranty

Structural modifications and incorrect installation which are not in accordance with these and our other instructions can result in serious injuries, e.g., crushing of limbs. Therefore, structural modifications may only be carried out with our prior approval and strictly in accordance with our instructions, particularly the information contained in these Assembly and Operating Instructions.

Any further processing of the products which does not comply with their intended use is not permitted.

The end product manufacturer and fitter have to ensure that all the relevant current statutory, official and, in particular, EMC regulations are adhered to during utilisation of our products, especially with regard to end product manufacture, installation and customer advice.

## Safety instructions

The following safety instructions and warnings are intended to avert hazards and to prevent property damage and personal injury.

## Instructions for the user

### General information

- The drive must be disconnected from its power source during cleaning and maintenance and when replacing parts.
- All work, including maintenance and cleaning, on electrical installations as well as other system parts must always be performed by trained technicians, in particular qualified electricians.

- Children from the age of 8 years and persons with reduced physical, sensory or mental capabilities or lack of experience and/or knowledge may use these devices, provided they are supervised or have been instructed in the safe use of the device, and have understood the hazards involved. Children must not play with the device.
- Systems have to be checked regularly by authorised specialists for wear and damage.
- Always put damaged systems out of operation immediately until they are repaired by an authorised specialist.
- Do not operate equipment if people or objects are within the danger zone.
- Observe the danger zone of the equipment during operation.
- Ensure that there is adequate clearance (at least 40 cm) between moving parts and adjacent objects.



### **Caution**

#### **Safety instructions for avoiding serious injuries.**

- **Crushing or shearing points must be avoided or protected.**

## **Instructions for installation and commissioning**

### **General information**

- Observe the safety instructions in EN 60335-2-97. Please note that this list of safety instructions is not exhaustive, since it would be impossible for the standard to include all sources of danger. For example, the design of the operated product, the way the drive works in the situation it is installed in or even the way the end product is mounted in the end user's place of use cannot be taken into consideration by the drive manufacturer.

If any questions or uncertainties regarding the safety instructions contained in the standard arise, please contact the manufacturer of the part or end product in question.

- All applicable standards and regulations for electrical installation must be complied with.



- All work, including maintenance and cleaning, on electrical installations as well as other system parts must always be performed by trained technicians, in particular qualified electricians.
- Only use spare parts, tools and accessory devices which have been approved by the drive manufacturer.  
Unapproved third-party products or modifications to the system and its accessories represent a risk to your safety and the safety of others. This means that the use of unapproved third-party products, or modifications which have not been agreed with or approved by us, are prohibited. We do not accept liability for damage or injury arising from such actions.
- Position switch with OFF presetting within sight of the driven product, but away from moving parts, at a height of over 1.5 m. This must not be publicly accessible.
- Permanently mounted control devices must be positioned where they can be seen.
- Rated torque and duty cycle must be suitable for the requirements of the driven product.  
Technical data - rated torque and service life can be found on the type plate of the tubular drive.
- Hazardous moving parts of the drive must be installed at a height of over 2.5 m above floor level or any other surface from which the drive can be accessed.
- To ensure safe operation of the system after commissioning, the limit positions must be correctly set/programmed in.
- Drives with a H05VV-F connecting cable may only be used indoors.
- Drives with a H05RR-F, S05RN-F or 05RN-F connecting cable may be used both indoors and outdoors.
- To connect the drive to the driven part, solely mechanical accessory components made by the drive manufacturer from the current product catalogue may be used. The components must be installed in accordance with the manufacturer's instructions.

- If the drive is used for shading solutions in a specially marked area (e.g., escape routes, hazard zones, safety areas), compliance with all applicable regulations and standards must be ensured.



### **Caution**

#### **Safety instructions for avoiding serious injuries.**

- **When electrical or electronic equipment and units are operated, certain components, e.g., the power supply unit, are live. Physical injuries or damage to property can result in the event of unauthorised interventions or failure to heed warnings.**
- **Be careful when touching the tubular drive, as it heats up during operation for technical reasons.**
- **Before installation, shut down all lines and control devices that are not essential for operation.**
- **Crushing or shearing points must be avoided or protected.**
- **When installing the drive, all-pole disconnection from the mains with a contact gap of at least 3 mm per pole must be provided (EN 60335).**
- **If the mains connecting cable is damaged, it may only be replaced by the manufacturer. If the drive has a plug-in connecting cable, it must be replaced with the same type of mains connecting cable, which is available from the drive manufacturer.**



## Attention

### Safety instructions for avoiding property damage.

- **Ensure that there is adequate clearance between moving parts and adjacent objects.**
- **The drive must not be carried by the mains connecting cable.**
- **All latching connections and fastening screws on the brackets must be checked to ensure that they are secure.**
- **Ensure that nothing rubs against the tubular drive, such as shading solution attachments, screws, etc.**

## Intended use

The type of tubular drive described in these instructions is intended solely for the operation of sun protection systems with locking systems. To function properly, these tubular drives need a fixed stop in the upper limit position (retracted blind).

It may only be used in networked systems if all the individual drives are exactly synchronised and reach the upper limit position at the same time.

For roller shutter applications, please use only the types of tubular drive designed for this purpose.

This type of tubular drive is designed for use in single systems (one drive per barrel).

The tubular drive must not be used in potentially explosive areas.

The connecting cable is not suitable for transporting the drive. Always carry the drive by the housing tube.

Other applications, uses and modifications are not permitted in order to protect the safety of the users and others, since these actions can impair the system's safety and carry the risk of personal injury and property damage. The drive manufacturer does not accept liability for damages or injury arising from such actions.

Always observe the information in these instructions when operating or repairing the system. The drive manufacturer does not accept liability for damage or injury resulting from improper usage.



## Assembling and disassembling the plug-in connecting cable

### Assembling the plug-in connecting cable

Insert the **dead** connecting cable into the drive head until the locating lug clicks into place in the drive. If necessary, use a suitable flathead screwdriver to assist with insertion. Set the screwdriver into one of the two plug grooves provided for this purpose. Check that the cable is properly engaged.

#### **C**-plug

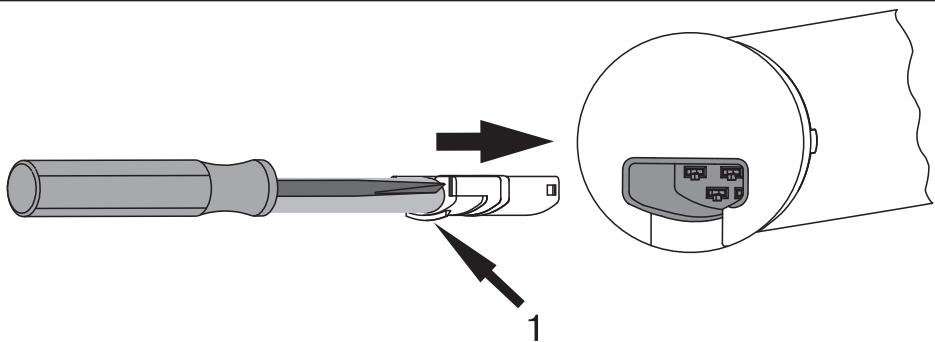

1 = locating lug

## Disassembling the plug-in connecting cable for tubular drives dia. 45 and dia. 58



### Caution

Prior to disassembly, the power supply to the connecting cable must be disconnected.

Insert a suitable flathead screwdriver right into the recess of the locating latch, so that the latch releases the locating lug from the plug.

Now you can pull out the connecting cable along with the flathead screwdriver.

dia. 45 and dia.  
58

**C\*plug**

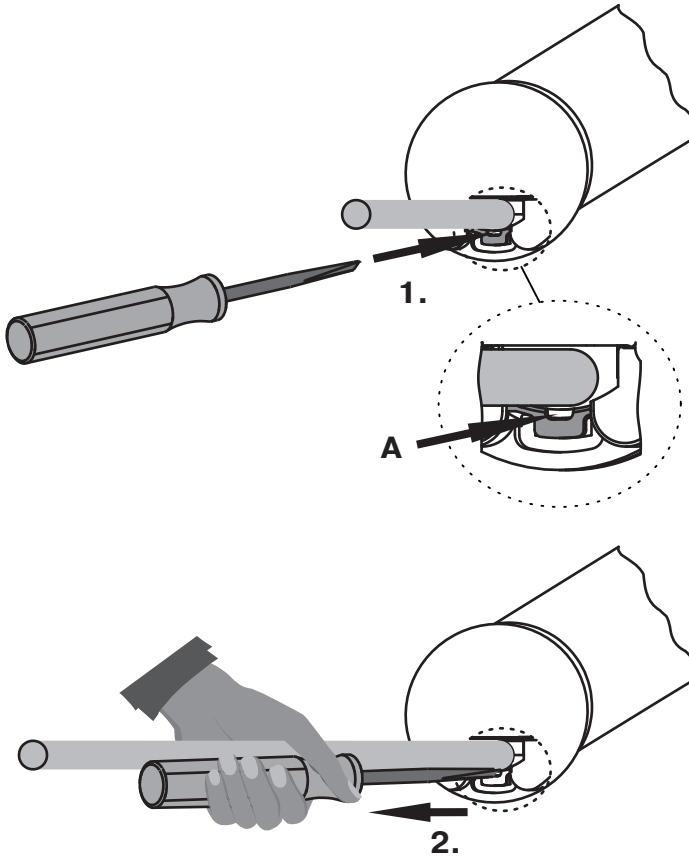

A = locating latch

# Installation

## Assembling the drive

### Attention

**To connect the drive to the driven part, solely mechanical accessory components made by the drive manufacturer from the current product catalogue may be used.**

Prior to mounting, the fitter must ensure that the masonry and the system being motorised are sufficiently robust (drive torque plus weight of the shading solution).



### Caution

**Electrical connections may only be carried out by a qualified electrician. Prior to assembly, the power supply must be disconnected and secured. Please give the enclosed connection information to the responsible electrical contractor.**

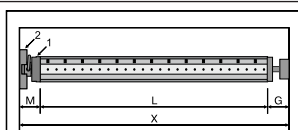

Calculate the space required at the side (M) by measuring the drive head (1) and wall bracket (2). The clear dimension of the box (X) minus the space required at the side (M) and idler (G) gives the length (L) of the barrel:  $L=X-M-G$ .

The space required at the side (M) varies depending on the combination of drive and wall bracket.

Then mount the wall bracket and idler. Ensure that the barrel is aligned at right angles to the wall and that sufficient axial play is allowed for the mounted system.

## Undoing the mounting pin

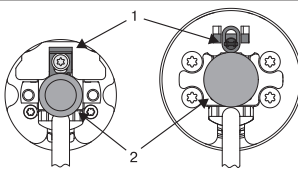

When pushed in, the mounting pin (2) locks automatically. To undo the mounting pin (2), push the tab washer (1) upwards and pull out the mounting pin (2).



## Drive adapter safety catch

### Assembling the drive adapter with safety catch on the drive shaft

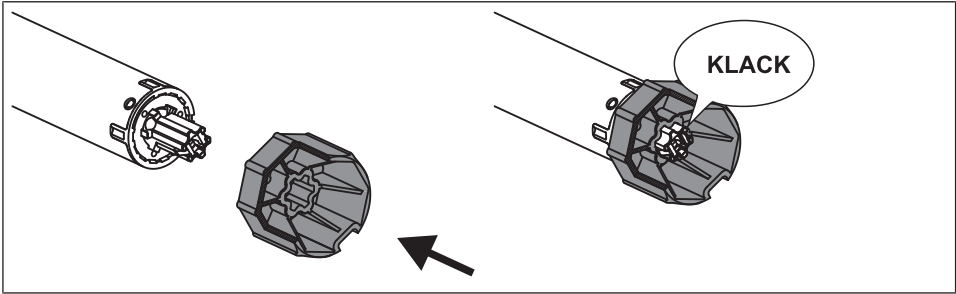

### Disassembling the drive adapter with safety catch on the drive shaft

Disassembly with disassembly tool, Item no. 4930 300 606 0

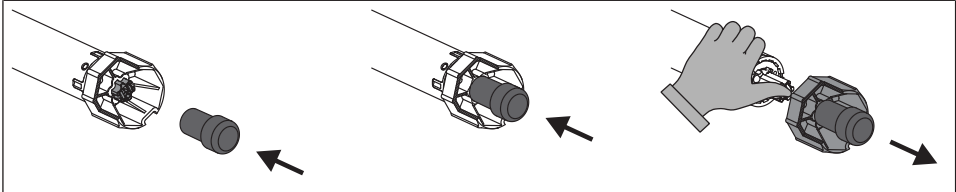

Disassembly with long nose pliers

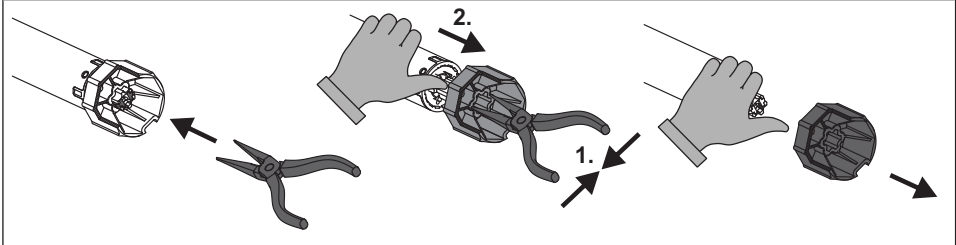

### Assembling and disassembling the drive adapter with separate drive adapter safety catch

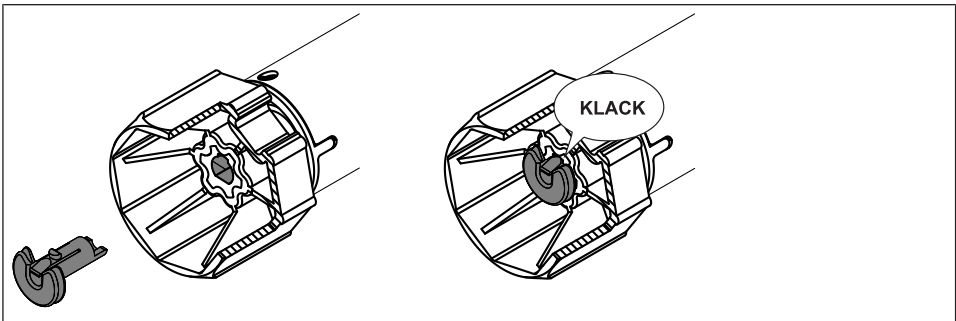

## Assembling and disassembling the drive adapter with screw connection

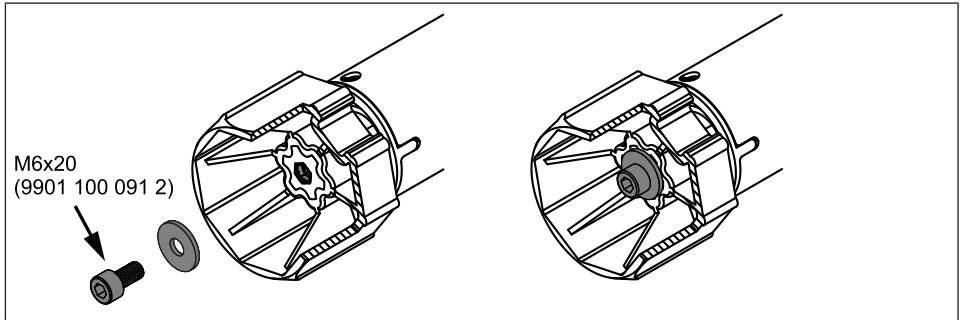

## Mounting the drive in the tube

	<p><b>For profile tubes:</b></p> <p>In the case of some drive adapters, tolerances of the groove widths in different barrels can be offset by rotating the drive adapter into a different groove recess. These groove recesses have different sizes and allow the drive to fit exactly.</p>
<p>X</p>	<p><b>For round shafts:</b></p> <p>Measure the lug of the thrust ring (X, Y). Then notch the tube on the motor side, so the lug of the thrust ring can also be pushed into the shaft. There must be no play between the lug of the thrust ring and the shaft.</p>
<p>10 mm</p>	<p>To ensure secure torque transmission for round shafts, we recommend screwing the drive adapter to the shaft (see the table below).</p> <p><b>Attention! When drilling into the barrel, never drill near the tubular drive!</b></p>



Size of drive [mm]	Drive adapter	Torque max. [Nm]	Fastening screws (4 units)
dia. 35-dia. 45	All	Up to 50	Self-tapping screw dia. 4.8 x 9.5 mm
dia. 58	Aluminium drive adapter	Up to 120	Countersunk screw M8 x 16 mm
dia. 58	diecast drive adapter	Up to 120	Self-tapping screw dia. 6.3 x 13 mm

We also recommend screwing the idler to the barrel.

### Attention

**Do not hammer the tubular drive into the tube or drop it into the barrel!**



Assemble the tubular drive with the relevant ring (1) and drive adapter (2). If the ring has several grooves, select the groove which is a perfect fit and push the ring (1) onto the thrust ring.

Insert the tubular drive with the pre-assembled ring (1) and drive adapter (2) into the tube to achieve a form fit. Ensure that the ring and drive adapter are secure in the tube.

Mount the assembled unit comprising barrel, tubular drive and idler on the box and secure the drive with a split or spring pin according to the type of wall bracket fixing.

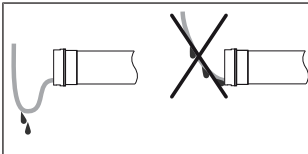

### Lay the connecting cable

Lay the connecting cable up to the tubular drive, and fix. The connecting cable and any antennae must not project into the winding chamber. Cover any sharp edges.

# Commissioning

## Explanation of symbols



**UP** button



**STOP** button



**DOWN** button



**Programming** button

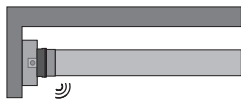

The tubular drive clicks once to confirm

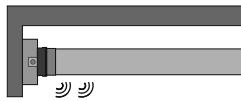

The tubular drive clicks twice to confirm

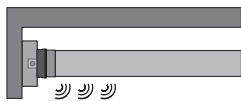

The tubular drive clicks three times to confirm

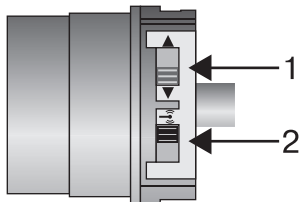

**1 = direction switch**

**2 = radio switch**



**Unlocked**



**Locked**

**Bolt**

**Moving part of the locking system on the front section of the sun protection system**

**Bolt mechanism**

**Fixed part of the locking system in the guide track of the sun protection system**



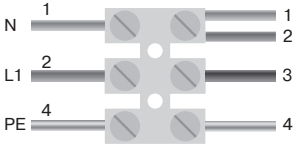

230V AC / 50 Hz			<b>Connecting the tubular drive</b> Connect the tubular drive to the power supply.
			
1 = blue	3 = black		<b>Readying the tubular drive for programming</b> Readying the tubular drive for programming by switching on the power <ul style="list-style-type: none"> <li>▷ Switch on the power.</li> <li>▶ The tubular drive is ready to programme for 3 minutes</li> </ul>
2 = brown	4 = green-yellow		

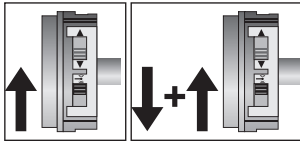
**i** If several tubular drives are to be connected in parallel, you can deactivate the programming mode on one tubular drive by switching the radio switch to the outside position after turning the power on.

	<b>Readying the tubular drive for programming with the radio switch</b> Switch the radio switch to the inside position. If the radio switch is already in this position, switch it to the outside and back to the inside position. <ul style="list-style-type: none"> <li>▶ The tubular drive is ready to programme for 3 minutes</li> </ul>
---	---

## Programming the master transmitter

		Press the programming button for 3 seconds when it is ready to programme. <ul style="list-style-type: none"> <li>▷ The tubular drive acknowledges.</li> <li>▶ The programming process is now complete.</li> </ul>
---	---	---





**If a transmitter is already programmed on the receiver, press the programming button for 10 seconds.**

## Checking that the running direction is correct

There are 2 ways to change the direction of rotation:

- Changing direction of rotation via rotation direction switch
- Changing direction of rotation via master transmitter

## Changing direction of rotation via rotation direction switch

Press the UP or DOWN button

- The shading solution runs in the desired direction
- ▶ The running direction is OK.

If the shading solution runs in the wrong direction, the running direction must be changed. Proceed as follows:

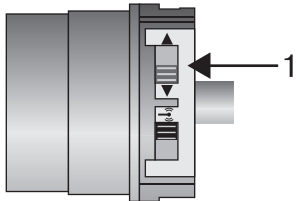

Switch the direction switch (1) to the opposite position.

- The running direction will now have changed.
- ▶ Check the running direction again.

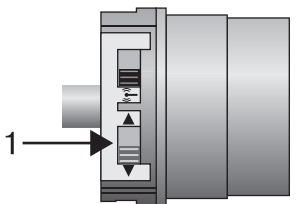

## Changing direction of rotation via master transmitter



**It is only possible to change the direction of rotation if no limit position has been set.**

Press the UP or DOWN button

- The shading solution runs in the desired direction.
- ▶ The running direction is OK.



If the shading solution runs in the wrong direction, the running direction must be changed. Proceed as follows:



First press the programming button and, within the next 3 seconds, press both the UP and DOWN buttons for 3 seconds.

- ▶ The tubular drive acknowledges.

Check the running direction again.

## Setting the limit positions

### Attention

The tubular drives are designed for short-time operation (for the operating mode, please see technical data). An in-built thermal protection switch prevents overheating of the tubular drive. During commissioning (long drop distance or long running time), the thermoswitch may trigger. The drive will switch off. After a short cooling-down period, the system is ready for operation again. The drive does not achieve its full duty cycle until it has cooled to ambient temperature. Avoid a situation where the thermal protection switch cuts in repeatedly.

**i** The limit positions can only be set with the master transmitter. The shutter direction must be correct. When setting the limit positions, the tubular drives runs in dead-man mode. If the tubular drive switches off prematurely while opening, due to an obstruction, the obstruction can be cleared by closing the screen and removing the obstruction. The upper limit position can be set by opening again.

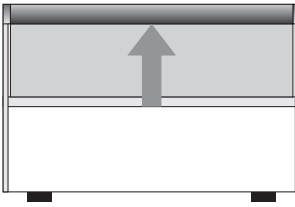
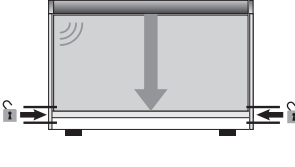
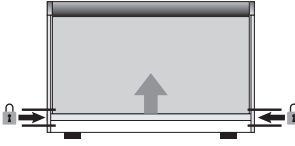
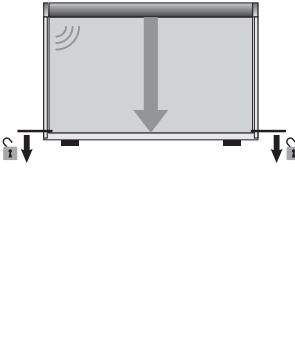
	<p><b>Installation step 1:</b></p> <p>First, press the UP button to retract to the upper limit position, until the tubular drive switches itself off .</p>
	<p><b>Installation step 2:</b></p> <p>Run the bolt past the locking point and stop the tubular drive. Now press the programming button and also the DOWN button for about 3 seconds. The tubular drive acknowledges and the locking limit position is saved.</p>
	<p><b>Installation step 3:</b></p> <p>Use the UP button to run the bolt in the open direction until it is engaged by the bolt mechanism. The tubular drive switches off automatically.</p>
	<p><b>Installation step 4:</b></p> <p>Use the DOWN button to run the bolt in the down direction and disengage it from the bolt mechanism, and then stop the tubular drive immediately. Now press the programming button and also the DOWN button for about 3 seconds. The tubular drive acknowledges and the un-locking limit position is saved.</p> <ul style="list-style-type: none"> <li>▶ Limit positioning is now complete.</li> </ul> <p>The blind will now lock and unlock automatically in the lower limit position when you close and open it.</p>



## Deleting the limit positions

### Attention

When the limit positions are deleted, all the other set functions (intermediate position I, intermediate position II) are deleted as well.

**i** Once set, the limit positions can only be deleted with the master transmitter.

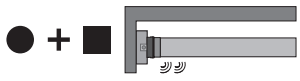
	<p>Press the programming button and, within the next 3 seconds, press the STOP button at the same time and hold the two buttons down for 10 seconds.</p> <ul style="list-style-type: none"><li>▶ The tubular drive acknowledges.</li><li>▶ The limit positions are now deleted.</li></ul>
--	---

## Intermediate position I in the down direction

**i** The intermediate position I is any shading solution position of your choosing. It is not possible to set an intermediate position I in the area of the limit position Both limit positions must be set before the intermediate position I is set. When both limit positions are deleted, this set function is deleted as well.

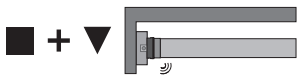

## Setting the intermediate position I

	<p>Travel the shading solution to the desired intermediate position I.</p>
	<p>Press the STOP button and, within 3 seconds, also press the DOWN button and hold the two buttons down.</p> <ul style="list-style-type: none"><li>▶ The tubular drive acknowledges.</li><li>▶ The intermediate position I is now saved.</li></ul>

## Checking the intermediate position I

2x		<p>Press the DOWN button twice within one second.</p> <ul style="list-style-type: none"> <li>▶ The shading solution runs to the intermediate position I.</li> </ul>
----	---	---

## Deleting the intermediate position I

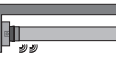
2x		<p>Move the shading solution to the intermediate position I.</p>
	 	<p>Press the STOP button and, within 3 seconds, also press the DOWN button and hold the two buttons down.</p> <ul style="list-style-type: none"> <li>▶ The tubular drive acknowledges.</li> <li>▶ The intermediate position I is now deleted.</li> </ul>





## Intermediate position II in the up direction



**The intermediate position II is any shading solution position of your choosing. It is not possible to set an intermediate position II in the area of the limit position. Both limit positions must be set before the intermediate position II is set.**

**When both or individual limit positions are deleted, this set function is deleted as well.**



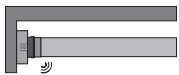

## Setting the intermediate position II

 / 	<p>Travel the shading solution to the desired intermediate position II .</p>
 +  	<p>Press the STOP button and, within 3 seconds, also press the UP button and hold the two buttons down.</p> <ul style="list-style-type: none"> <li>▶ The tubular drive acknowledges.</li> <li>▶ The intermediate position II is now saved.</li> </ul>

## Checking the intermediate position II





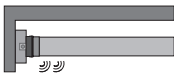

2x		<p>Press the UP button twice within one second.</p> <ul style="list-style-type: none"> <li>▶ The shading solution runs to the intermediate position II.</li> </ul>
----	---	--

## Deleting the intermediate position II

2x		<p>Move the shading solution to the intermediate position II.</p>
	  	<p>Press the STOP button and, within 3 seconds, also press the UP button and hold the two buttons down.</p> <ul style="list-style-type: none"> <li>▶ The tubular drive acknowledges.</li> <li>▶ The intermediate position II is now deleted.</li> </ul>

## Programming additional transmitters

**i** In addition to the master transmitter, up to 15 further transmitters can be programmed in the tubular drive. Before programming a radio controlled Sun-Wind-Sensor, the limit positions must be programmed.

		<p>Press the programming button of the master transmitter for 3 seconds.</p> <ul style="list-style-type: none"> <li>▶ The tubular drive acknowledges.</li> </ul>
		<p>Now press the programming button of a new transmitter which has not yet been programmed in the tubular drive for 3 seconds. Doing so activates the programming mode of the tubular drive for a new transmitter for 3 minutes.</p> <ul style="list-style-type: none"> <li>▶ The tubular drive acknowledges.</li> </ul>
		<p>Now press the programming button of the new transmitter you wish to program again for 3 seconds.</p> <ul style="list-style-type: none"> <li>▶ The tubular drive acknowledges.</li> <li>▶ The new transmitter has now been programmed.</li> </ul>

## Deleting transmitters

### Deleting individual transmitters



**The programmed master transmitter cannot be deleted. It can only be overwritten (see Programming the master transmitter [▶ 16]).**

●		<p>Press the programming button on the master transmitter for 3 seconds.</p> <ul style="list-style-type: none"> <li>▷ The tubular drive acknowledges.</li> </ul>
●		<p>Now press the programming button of the transmitter to be deleted for 3 seconds.</p> <ul style="list-style-type: none"> <li>▷ The tubular drive acknowledges.</li> </ul>
●		<p>Then press the programming button of the transmitter to be deleted again for 10 seconds.</p> <ul style="list-style-type: none"> <li>▷ The tubular drive acknowledges.</li> <li>▶ The transmitter is now deleted from the tubular drive.</li> </ul>

### Deleting all transmitters (except the master transmitter)

●		<p>Press the programming button on the master transmitter for 3 seconds.</p> <ul style="list-style-type: none"> <li>▷ The tubular drive acknowledges.</li> </ul>
●		<p>Re-press the programming button on the master transmitter for 3 seconds.</p> <ul style="list-style-type: none"> <li>▷ The tubular drive acknowledges.</li> </ul>
●		<p>Re-press the programming button on the master transmitter for 10 seconds.</p> <ul style="list-style-type: none"> <li>▷ The tubular drive acknowledges.</li> <li>▶ All transmitters (except the master transmitter) are now deleted from the receiver.</li> </ul>



## Overwriting the master



There are two ways to overwrite the master:

- Readyng the tubular drive for programming by switching on the power
- Readyng the tubular drive for programming with the radio switch

### Readyng the tubular drive for programming by switching on the power



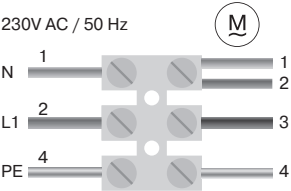

To ensure that the new master transmitter is programmed in the desired tubular drive only, all other tubular drives which are connected to the same power supply must be deactivated from the programming mode. To do so, after switching back on the power, execute a drive or stop command using the transmitter for the given tubular drives or switch the radio switch from inside to outside. If the radio switch is already in this position, switch it to the inside and back to the outside position.

<p>230V AC / 50 Hz</p>  <p>1 = blue 2 = brown 3 = black 4 = green/ yellow</p>	<p>Switch off the tubular drive power for 5 seconds, then switch it back on.</p> <ul style="list-style-type: none"><li>▶ The tubular drive is ready to program for 3 minutes.</li></ul>
 	<p>Now press the programming button of the new master transmitter for 10 seconds.</p> <ul style="list-style-type: none"><li>▶ The tubular drive acknowledges.</li><li>▶ The new master transmitter has now been programmed and the old master transmitter overwritten.</li></ul>

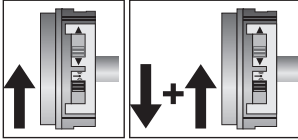

## Readying the tubular drive for programming with the radio switch

	<p>Switch the radio switch to the inside position. If the radio switch is already in this position, switch it to the outside and back to the inside position.</p> <ul style="list-style-type: none"><li>▷ The tubular drive is ready to program for 3 minutes.</li></ul>
	<p>Now press the programming button of the new master transmitter for 10 seconds.</p> <ul style="list-style-type: none"><li>▷ The tubular drive acknowledges.</li><li>▶ The new master transmitter has now been programmed and the old master transmitter overwritten.</li></ul>

## Disposal

This product is made of various materials which must be disposed of properly. Find out about the applicable regulations on recycling or disposal for this product in your country.

The packaging material must be disposed of properly.

## Maintenance

These drives are maintenance-free.



## Technical data dia. 45

Type	R8/17 C SEF I1	R12/17 C SEF I1	R20/17 C SEF I1	R30/17 C SEF I1	R40/17 C SEF I1
Rated torque [Nm]	8	12	20	30	40
Output speed [rpm]	17	17	17	17	17
Limit switch range	64 revolutions				
Supply voltage	230 V AC / 50 Hz				
Connected load [W]	100	110	160	205	260
Rated current consumption [A]	0.45	0.50	0.75	0.90	1.15
Mode	S2 4 min				
Degree of protection	IP 44				
Min. tube inside diameter [mm]	47				
Frequency	868.3 MHz				
Emission sound pressure level [dB(A)]	≤ 70				

## Technical data dia. 58

Type	L50/17 C SEF I1	L70/17 C SEF I1	L80/11 C SEF I1	L80/17 C SEF I1*	L100/11 C SEF I1	L120/11 C SEF I1
Rated torque [Nm]	50	70	80	80	100	120
Output speed [rpm]	17	17	11	17	11	11
Limit switch range	64 revolutions					
Supply voltage	230 V AC / 50 Hz					
Connected load [W]	315	430	310	470	354	435
Rated current consumption [A]	1.40	1.90	1.40	2.10	1.56	1.90
Mode	S2 4 min					
Degree of protection	IP 44					
Rated torque [Nm]	60					
Frequency	868.3 MHz					
Emission sound pressure level [dB(A)]	≤ 70					

\*) This tubular drive is not yet available.



## What to do if...?

Problem	Remedy
Tubular drive is not functioning.	Program new transmitter.
	Bring transmitter within range of the tubular drive.
	Press drive or stop button on transmitter at least 5 times.
	Insert batteries correctly or insert new batteries.
	Check electrical connection.
	Thermal protection switch in tubular drive has tripped. Wait 5-10 mins.
Shutter direction on tubular drive cannot be set.	Delete limit positions (see Deleting the limit positions [▶ 20]) and reset the shutter direction.
Incorrect shutter direction after deleting limit positions.	Change the shutter direction using the master transmitter or the direction switch on the tubular drive.
Tubular drive stops arbitrarily; cannot be restarted in the same direction.	Tubular drive has detected an increase in load. Briefly run the curtain in the opposite direction, then continue in the desired direction.
	Tubular drive is overloaded. Use a higher-torque tubular drive.
Tubular drive is not locking. Tubular drive automatically approaches the locking point 3 times.	The locking point is not correctly programmed. Re-program limit positions.
Tubular drive is not unlocking. Tubular drive automatically approaches the unlocking point 5 times.	The unlocking point is not correctly programmed. Re-program limit positions.

# Declaration of conformity

BECKER-ANTRIEBE GMBH  
Friedrich-Ebert-Str. 2-4  
35764 Sinn, Germany



**BECKER**

- Original -

## EU Declaration of Conformity

Document No./Month . Year: **K004/01.18**

We hereby declare that the following product series

Product designation: **Tubular motor**

Type designation: **P3/30.., P4/16.., P5/16.., P5/20.., P5/30.., P9/16.., P13/9.., R7/85.., R8/17.., R12/17.., R18/11.., R20/17.., R30/11.., R30/17.., R35/11.., R40/17.., R50/11.., L44/14.., L50/11.., L50/17.., L60/11.., L60/17.., L70/17.., L80/11.., L80/17.., L100/11.., L120/11..**

Version: **C, R, S, F, P, E, O, A0...Z9, +**

From serial number: **from 180200001**

complies with the applicable regulations of the following Directives:

**Directive 2006/42/EC (MD)**

**Directive 2014/53/EU (RED)**

**Directive 2011/65/EU (RoHS)**

Furthermore, the safety objectives of the **Low Voltage Directive 2014/35/EU** as per Appendix I No.1.5.1 of Directive 2006/42/EC have been met.

Applied standards:

**EN 60335-1:2014**

**EN 60335-2-97:2015**

**EN 61000-6-3:2011**

**ETSI EN 301489-3:2013**

**EN 14202:2004**

Authorised party for the compilation of the technical documentation:

Becker-Antriebe GmbH, Friedrich-Ebert-Str. 2-4, 35764 Sinn, Germany

This declaration of conformity was issued:

Sinn, 05.01.2018

Place, Date

  
Dipl.-Ing. Dieter Fuchs, Management

This declaration certifies compliance with the Directives cited but does not represent any assurance of characteristics.

The safety warnings in the supplied product documentation must be observed!



**BECKER**







**BECKER**